



INSTALLATION PROCEDURE

FOR SPC-24

PHOTOELECTRIC

BEAM DETECTOR

Contents

Contents	2
1. General Description	4
1.1. Detection principle	4
2. Installing the detector	5
2.1. Siting	5
2.2. Mounting and removing the detector	6
2.3. Opening the detector cover	7
2.4. Installation	7
2.4.1. Installation option	7
2.4.2. Installation procedure	8
2.5. Closing the detector cover	11
2.6. Adjustment procedure	11
2.6.1. Alignment adjustment	11
2.6.2. Setting the Sensitivity & Switches for Operation	12
2.6.3. Signal strength adjustment	13
2.7. Sensitivity check procedure	14
3. Maintenance	15
3.1. General	15
3.2. Visual check	15
3.3. Operation checks	15
3.4. Precautions for insulation resistance checking	15
3.5. Re-initialisation after cleaning or re-adjustment	15
4. Terminal layout and part designation	16
4.1. Emitter	16
4.2. Receiver	16
5. Summary of the SPC-24's functions	17
5.1. Alarm signal output and indicator lamp	17
5.2. Fault signal output and indicator lamp	17
5.2.1. General	17
5.2.2. After adjustment/re-initialisation	17
5.2.3. During normal operation	17
5.3. Indication of normal operation	18
5.4. Sensitivity and operation setting	18

5.5. Total obscuration of the beam	18
5.6. Automatic compensation for change of receiver's signal strength	18
6. Specification	19
7. Sensitivity selection	20
8. Troubleshooting	21
8.1. Operating indicator LED fails to flash	21
8.1.1. Receiver	21
8.1.2. Emitter	21
8.2. Fire signal continues after reset	21
8.3. Fault signal cannot be reset	22
8.4. Detector generates fire - panel does not register condition	22
8.5. Detector generates a fault - panel does not register condition	22
9. Installation guide lines	23
9.1. General installation conditions	23
9.2. Installation in Saw-tooth type ceilings	24
9.3. Installation in circular type ceilings	24
9.4. Installation in sloped ceilings	24
9.5. Installation in a monitor roof	25
9.6. Installation in corridors or aisles	25
9.6.1. Closed corridor	25
9.6.2. Corridor with open adjoining aisle	26
9.6.3. Corridor with corners	26
9.7. Installation precautions	27
9.8. Smoke Patterns	28

1. General Description

The photo-electric beam detector consists of an emitter and a receiver which face each other at a distance of between 5 and 100 meters.

In the event of fire the smoke generated will decrease the amount of near infra-red light incident on the receiver. This decrease is electronically interpreted to identify the occurrence of fire. An important feature of the detector is that it monitors the protected space linearly. This enables the detector to identify a fire before it spreads, even when the smoke is scattered over a large area.

The fire detection sensitivity is switch selectable in 3 settings of 25%, 50% and 70% beam obscuration.

1.1. Detection principle

A near infra-red pulsed beam generated by the emitter is sensed by the photo-diode of the receiver, where it is converted into an electrical signal. This signal is then amplified and applied via an A/D converter to a micro-processor. The normal state signal (the initial beam data) once stored in the micro-processor is used as a reference for comparison with subsequent beam signals.

When there is sufficient difference between actual beam strength and stored reference data to indicate the occurrence of a fire, then a fire signal is produced. If an obstacle blocks the beam, thus abruptly reducing the received beam level, a fault signal is emitted. (The detector can be set to emit a fire signal after emitting a fault signal.) The same error signal is emitted when reception signals increase abruptly.

The micro-processor also provides compensation for a change in received signal value with time, caused by contamination of the optics or slight alignment changes. The processed signal is adjusted at a rate of $\pm 1\%$ towards the reference data every 30 minutes. When the limit of compensation is reached the micro-processor will automatically produce a fault signal.

In order to improve the performance of the detector and to enhance the rejection of noise the emitter and receiver are synchronised together. The emitter and receiver are automatically synchronized by using near-infrared beams produced by the emitter. The emitter and receiver therefore do not need to be interconnected.

Principle of operation

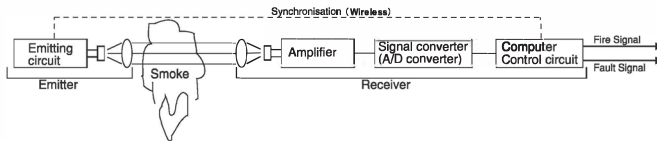

2. Installing the detector

2.1. Siting

Select a suitable position for the installation of both emitter and receiver, such that there are no visible obstructions between them. Remember that the beam detector works on the principle of reduction of light between the receiver and emitter. If there is any possibility of an object remaining within the beam for a few seconds then the siting of the detector is unsuitable.

For mounting either the emitter or receiver it is important to establish that the mounting place such as the wall is solid and that the beam detector alignment will be rigid. The wall may appear to be solid, but may be subject to twisting or other changes when the temperature outside the building varies greatly during one day, for instance on cold, frosty days. The installer must ensure that the beam will not be subject to misalignment due to changes in the building itself.

The spacing and siting in specific types of locations is covered in section 9.

The beam detector must not be installed in the following locations :-

- ▶ Where the ceiling height is greater than 40m
- ▶ A roof top or place where open air circulates
- ▶ Where the distance between top and bottom of the space is less than 0.5m
- ▶ In locations where a large amount of dust, fine powder or water vapour is present
- ▶ In locations such as kitchens where smoke occurs normally
- ▶ In locations which are exposed to extremely high temperatures
- ▶ Where access to the detector is impossible for maintenance purposes
- ▶ In locations which may be exposed to sunlight exceeding 5000 lux. It is recommended that in locations where the beam detector may be surrounded by glass, then the receiver should where possible be fitted so that it faces a northerly direction (only relevant to countries in the northern hemisphere)
- ▶ Where the rigid fixing of either the emitter or receiver is impossible
- ▶ Where access to the beam detector to align and set is impossible
- ▶ Where 2 or more xenon lights continuously flash in view of Receiver

2.2. Mounting and removing the detector

The detector can be fixed to the metal bracket by hooking the detector body to the four prongs of the mounting plate and then by sliding down firmly until the detector is locked into place and then locking using the locking screw. (see Figure 1).

Removal of the detector can be achieved by slackening the locking screw and pressing the locking mechanism located on the bottom left hand side of the detector housing. Whilst pushing the locking mechanism with either a narrow rod or screw driver the detector is lifted upwards until it disengages from the mounting plate.

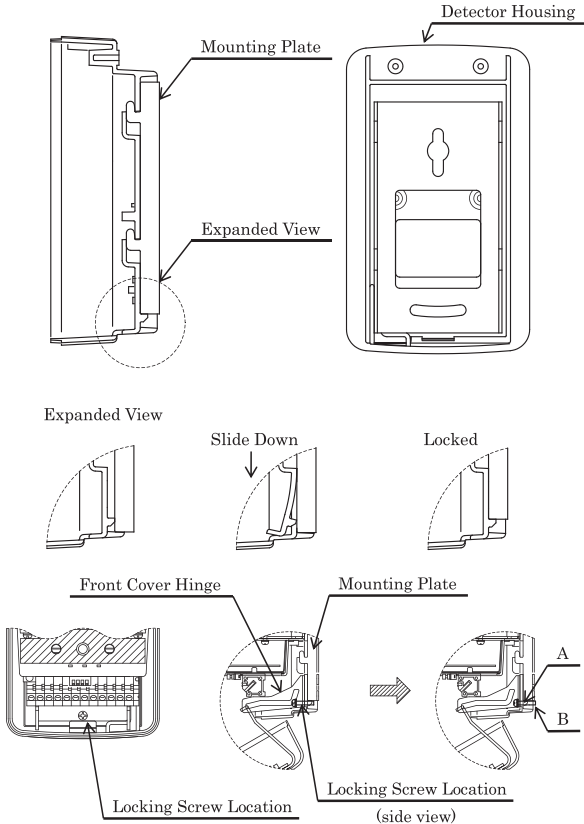

A: After mounting the detector to the mounting plate, install the locking screw.

B: Prevents removal of the detector from the mounting plate.

Figure 1 Locking mechanism

2.3. Opening the detector cover

Hold the detector cover between the thumb and fingers near the top of the cover and squeeze the cover firmly so that the top of the cover expands slightly. The cover can then be pulled away from the detector housing. This should be done by pulling the cover at an angle of 45° upwards and away from the detector.

Next hold the detector cover firmly at the bottom and pull away from the detector housing until a click is heard. The cover should now be able to drop down and rest on the cover retaining clips, thus allowing access inside the detector housing. Refer to Figure 2 for more details.

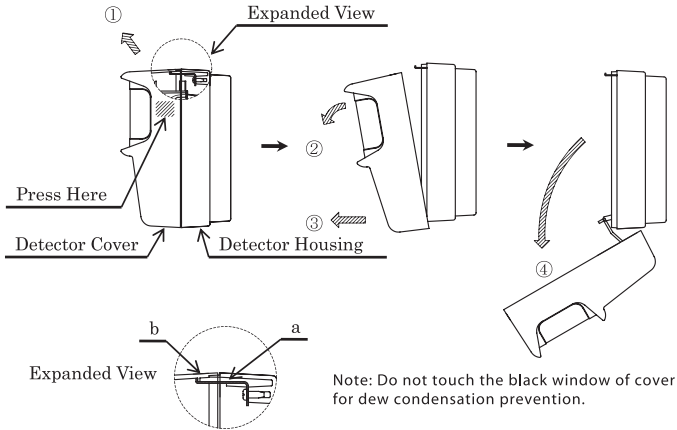

Figure 2 Opening the detector housing

2.4. Installation

Refer to section 2.4.1 for installation details:

- 1 Emitter
- 1 Receiver
- 2 Metal mounting brackets
- 1 Installation manual
- 4 Fixing screws

2.4.1. Installation option

It is possible to connect the beam detector as a 4-wire system (Figure 6).

The receiver alone emits signals when there is a fire. The emitter can therefore be equipped with a local power supply. Power supply should be an ANSI/UL 1481 UL Listed Power Supplies for Fire-Protective Signaling Systems (24VDC/50mA).

The Emitter is supervised through the receiver if the emitter or the separate power supply was to not function.

2.4.2. Installation procedure

Screw the detector mounting plate firmly to the wall or other suitable mounting point. Pull the cable out about 6 inches from the wall and strip 5 inches of the outer insulation jacket. Push cable wires through the hole in the back side of the SPC-24. The SPC-24 will accept wire sizes ranging from 14 to 20 AWG.

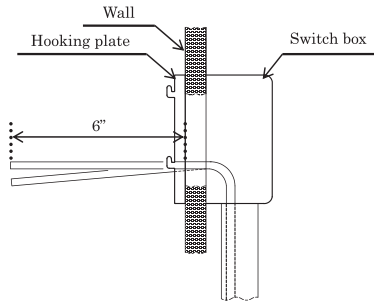

Figure 3 Wiring method (1)

Open the detector cover as described in section 2.3 and then take the wires into the back of the detector through the hole so that they come out below the terminal connector.

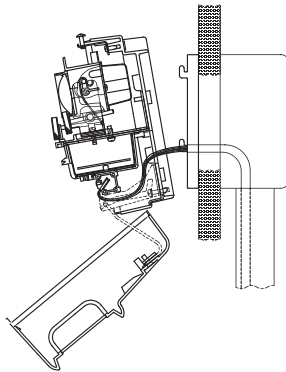

Figure 4 Wiring method (2)

After wiring, pull the cable tight to take up the slack. Push any excess wire lengths toward the back of the detector. Be careful not to catch the wires on the detector cover. Finally, push any excess wire lengths into the electrical box and mount the detector onto the mounting plates.

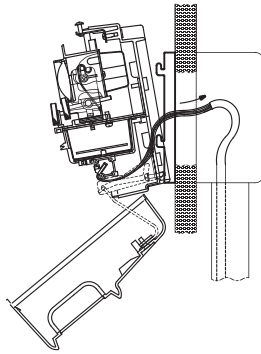

Figure 4 Wiring method (3)

Hook the back of the detector body to the 4 prongs of the mounting plate and slide down firmly, ensuring that the cables are not trapped or damaged by the detector. The detector body should lock into place by the locking mechanism which is located on the bottom right hand corner of the detector and then secured using the locking screw. Refer to the mechanical drawing Figure 1.

Connect the wires which run from the receiver to the emitter. The wiring method is shown in the wiring diagrams Figure 6. The receiver alone emits signals when there is a fire. The emitter can therefore be equipped with a local power supply.

The wires should be pushed into the holes of the connector whilst the white push key is pressed with a small screwdriver. This will enable the wire to push completely home. Pull the wire to make sure that it is firmly held by the connector.

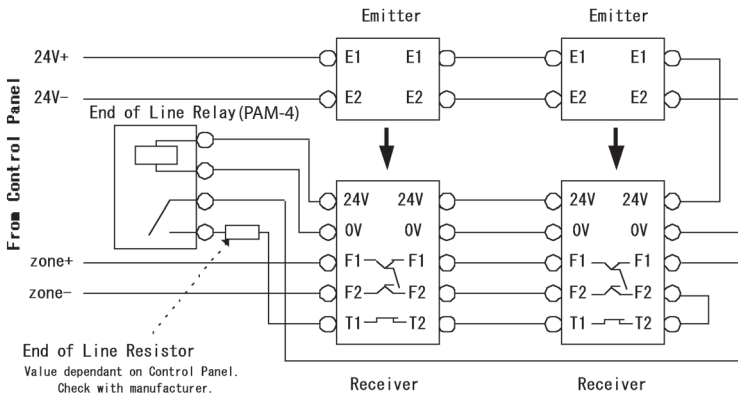

Figure 6 Wiring diagram for 4-wire connection

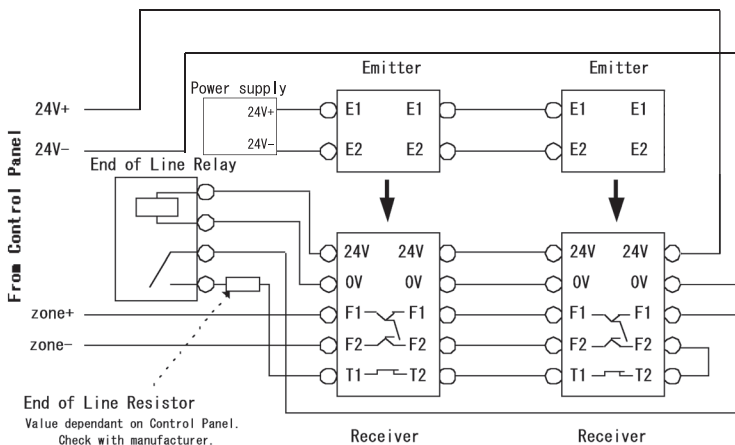

Figure 6' Wiring diagram for 4-wire connection
(Power to Emitters from separate supply)

In order to comply with regulations for device and wiring supervision it may be necessary to use an end of line relay and end of line resistor. Also the contact across the detection zone for fire is a relay contact and it will generally be necessary to include a resistor or other current limiting element in series with the relay contact.

Because the beam detector is powered by a separate line from the control panel it will be necessary to reset this power line to remove a fire condition from the beam detector.

The connections for the emitter and receiver are detailed below. The terminal names are marked above the terminals on the beam detector. Refer to section 4 for a drawing of the terminal positions.

Emitter:

E1, E2 Zone or Power (in/out) (Non Polarized)

Receiver:

F1, F2 - Fire alarm output contacts. Normally open

T1, T2 - Fault output contacts. Normally closed

24V, 0V - Beam detector power supply

Now set up the beam as described in sections 2.6 and 2.6.2.

2.5. Closing the detector cover

Move the cover upwards so that the cover engages with the top of the detector housing. Then hook the top of the cover over the metal hook protruding outward from the top of the detector housing. Pull down the top of the cover ensuring that it is flush with the detector housing top. Now push the cover at the bottom firmly towards the detector housing until it locks back into place. Refer to Figure 8 for more details.

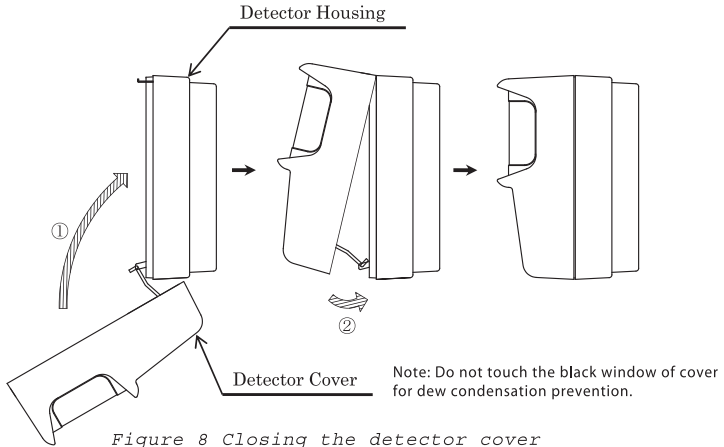

Figure 8 Closing the detector cover

2.6. Adjustment procedure

Adjust the detector as follows:

- Use the sight hole and optical axis control to adjust the optical axis of the emitter.
- Set the distance switch on the emitter according to the monitoring distance and close the cover of the emitter.
- Use the sight hole and optical axis control to adjust the optical axis on the receiver.
- Set the sensitivity of the receiver and close the cover.

Closing the cover on the receiver will automatically synchronize the receiver with the emitter. The level of the reception signal is automatically adjusted to initiate fire monitoring. It takes about two minutes for fire monitoring to begin after the receiver cover is closed. In the meantime, take care not to block the beam. Refer to section 4 for details of the position of the relevant parts on the detector when making the following adjustments.

2.6.1. Alignment adjustment

Open the covers of the emitter and receiver as described previously. At the receiver confirm that both sensitivity setting switches SW1 and SW2 are set to OFF (sensitivity off), refer to Figure 10. Power up the receiver and emitter and then wait two minutes for the beam detector to stabilise. At this time the green operating LED will flash in synchronisation with the green alignment setting LED once every 3 second.

Move to the emitter and look through the alignment sight hole. Turn either the horizontal or vertical alignment screws until the receiver can be seen in the centre of the sight hole.

When installing the units in a dimly lit area, it may be difficult to see the receiver and emitter. In this case alignment can be made by turning the alignment adjustment wheels until the alignment setting LED can be seen in the centre of the sight hole.

Set the distance switch on the emitter according to the monitoring distance, then close the cover on the emitter. Then adjust the optical axis on the receiver similarly. (refer to figure 12).

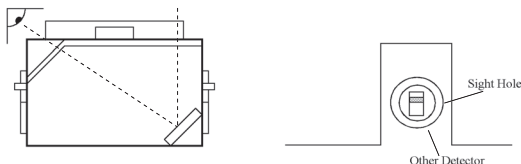

Figure 9 Detector alignment

When necessary, the optical axis can be fine-tuned as follows:

With the emitter cover open, hold down the push switch (see Chapter 4) for about five seconds, then release it. Then the monitor lamp (green) and fault lamp (yellow) on the receiver will start blinking at intervals of three seconds. (During that time, synchronization is being established with the emitter.) After that, in addition to the monitor lamp (green) and the fault lamp (yellow), either of the monitor LEDs* (yellow, green, and red) will start to blink. (During that time, the reception level is automatically adjusted.) When the automatic adjustment of the reception level is successfully terminated, the fault lamp (yellow) will go out and then the monitor lamp (green) and the green monitor LED will start to blink. When that happens, the monitor LED can be used as a level meter for reception signals. Turn the optical axis control to maximize the reception signal. When synchronization is established with the emitter, every push of the push switch for about five seconds will adjust the reception level automatically.

*These LED's are small square LED's located in the main PCB and are located below the main alignment and status LED's (refer to section 2.5). If the signal stays always in the yellow LED region then the signal strength is too weak. If the signal stays always in the red LED region then the signal strength is too high. Twice flashing is stronger than once flashing. If the cover will be closed(push switch will keep being pushed) then signal strength will be adjusted automatically, and signal will stay always in the green LED region.

2.6.2. Setting the Sensitivity & Switches for Operation

Set the distance range using switches of the emitter SW1 and SW2 according to the distance of emitter to receiver. The range for the positions of SW1 and SW2 are shown in Figure 10 together with a front view of the on and off positions as viewed with the detector in its normal installation orientation.

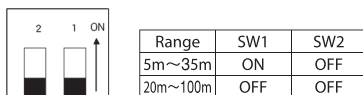

Figure 10 Distance range setting

Set the sensitivity to the required value using switches of the receiver SW1 and SW2 according to the distance and ceiling height. SW4 is switch for operation. The sensitivity for the positions of SW1 and SW2, operational mode for the position of SW4 are shown in Figure 11.

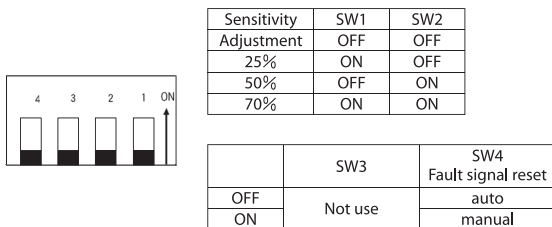

Figure 11 Sensitivity and operation setting

2.6.3. Signal strength adjustment

The reception signal level can automatically be initiated by closing the cover on the receiver. Before closing the cover on the receiver, check if the sensitivity and functional switches and the distance switch on the emitter (see Chapter 2.6.2) are appropriately set. Closing the cover on the receiver synchronizes the receiver with the emitter, then automatically adjusts the amplification factor of the reception circuit, then initiates fire monitoring. While synchronization is being established with the emitter and while the reception signal level is automatically adjusted, the monitor lamp (green) and fault lamp (yellow) on the receiver blink at intervals of three seconds. If the system shifts successfully to the monitoring state, the monitor lamp (green) alone will blink. If synchronization is not successfully adjusted, the fault lamp (yellow) alone will blink, emitting a fault signal. The status (normal monitoring, fault, fire, or other) of the detector can be checked by the lamps on the receiver. The lamps on the emitter do not change their condition with the status of the detector. The status of the detector corresponds to the displays as indicated in Table 1.

	Receiver				Emitter	
	Monitor lamp/fire lamp (green/red)	Optical axis lamp (green)	Fault lamp (yellow)	Monitor LED (yellow/green/red)	Monitor lamp (green)	Optical axis lamp (green)
Optical axis adjustment in progress (when the power is turned on)	○(green)	○*1			○	○*1
Synchronization in progress	○(green)		○		○	○*1
Automatic adjustment in progress	○(green)		○	○*1	○	○*1
Monitoring in progress	○(green)				○	○*1
Fire	●(red)				○	○*1
Fault	○(green)		○		○	○*1

○Blinking (at intervals of three seconds) ●Lit

*1: Closing the cover hides the lamp.

Table 1 Status display of the detector

If the detector goes into fault after initialisation the following conditions may have occurred :-

- ▶ The cover of the receiver was closed, but the sensitivity was left OFF
- ▶ The sensitivity has been set but the cover of the receiver was not closed
- ▶ The light level is too low or too high reaching the beam
- ▶ The distance setting switch of the emitter has not been set correctly

Run through the alignment and signal strength procedure again until the beam detector will initialise correctly.

2.7. Sensitivity check procedure

After installing the detector or during periodic maintenance it is important to ascertain that the detector has the correct fire sensitivity. This can be achieved by the use of filter (SPB-24N).

SPB-24N filters have been designed as disposable test filters for testing the Hochiki SPB-24N or SPC-24 beam detector and have been manufactured from plastic.

First determine the sensitivity that the beam detector should be set to and then select the correct filter values from Table 2. Using the lowest filter value prove that the detector is not too sensitive by placing the filter between the emitter and receiver for at least 30 seconds. It is not set to the correct sensitivity if the detector goes into fire alarm (or fault) during this process.

Next place the higher value filter between the emitter and receiver for at least 30 seconds. During this period a fire alarm should occur. If no alarm occurs or a fault occurs then the detector is not operating as expected.

Sensitivity Setting	Filter Label	Obscuration Value	
		No Alarm	Alarm
25%	25%/Span	15%	37%
50%	50%/Span	37%	65%
70%	70%/Span	45%	80%

Table 2 Test filter values

3. Maintenance

3.1. General

The detector contains an automatic compensation function, which allows the detector to operate correctly even when the amount of signal reaching the receiver has changed (the compensation rate is $\pm 1\%/30$ minutes). This means that minor changes due to contamination and beam alignment will not affect the sensitivity of the detector. There is of course a limit that the detector can compensate for and this is -50% and +50% of the initial setting. In order to maintain proper performance the detector should be checked every six months.

3.2. Visual check

Check the condition of both the emitter and receiver for physical damage or any other condition that might impair proper operation. Ensure that both the receiver and emitter are still firmly secured to the wall or other fixing point.

If necessary clean the lens cover with a damp soft cloth. Washing liquid or detergent must not be used.

3.3. Operation checks

Perform the sensitivity check function as defined in section 2.7.

3.4. Precautions for insulation resistance checking

If the wiring to a beam detector is to be tested for insulation resistance using a high voltage tester such as a Megger, the wiring to the beam detector must be disconnected from the detector otherwise permanent damage of the detector may result.

3.5. Re-initialisation after cleaning or re-adjustment

The detector incorporates non-volatile memory, where backup copies of the initial settings and dirt progress are periodically made. This memory is retained even after the power is turned off. Turning the power off and back on will cause the detector to reload the settings which were in the memory before the power was turned off, then to shift to the monitoring state.

To clean the cover, readjust the optical axis, or do something similar during maintenance work, the memory must be cleared. The memory can be cleared in either of the following two ways:

- Open the cover on the receiver while in a normal monitoring state.
- Turn on the power with the receiver cover open.

4. Terminal layout and part designation

4.1. Emitter

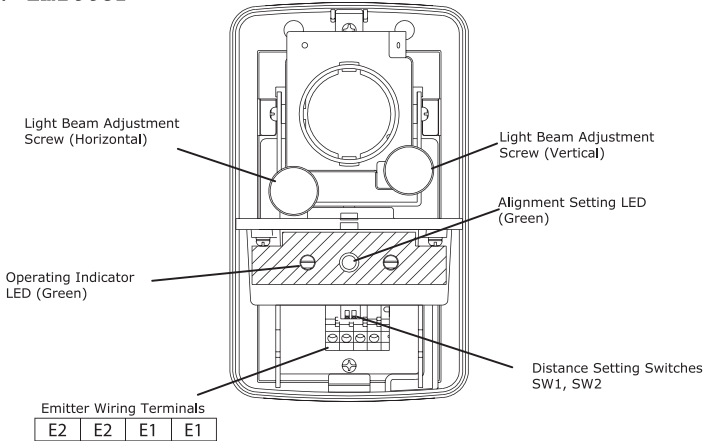

Figure 12 Emitter Construction

4.2. Receiver

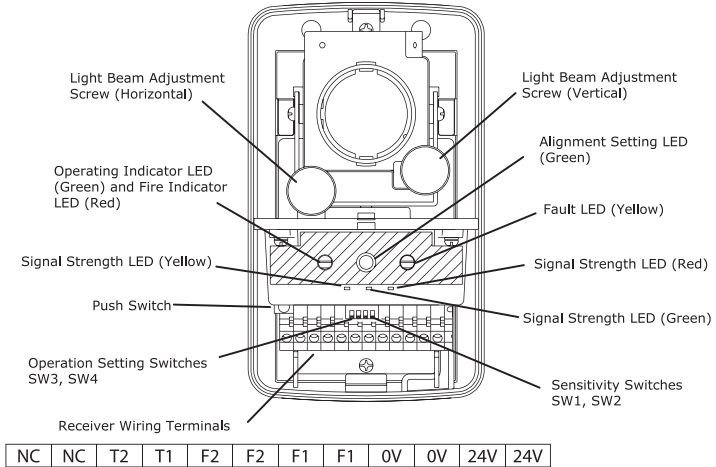

Figure 13 Receiver Construction

5. Summary of the SPC-24's functions

5.1. Alarm signal output and indicator lamp

When the beam is obscured by an amount that exceeds the sensitivity setting of the detector then a fire signal is produced and lighting the fire LED on the receiver.

It should be noted that the SPC-24 has a sophisticated processing and analysing circuit and therefore a fire will not occur immediately the obscuration exceeds the sensitivity value, but will take typically 10 to 15 seconds to produce the fire signal. The fire decision is based on an averaging technique and therefore the time to fire alarm will vary depending on the level of obscuration and the sensitivity setting.

5.2. Fault signal output and indicator lamp

5.2.1. General

The beam detector may produce a fault condition for one of many different reasons, which will depend on whether the detector has just been set up or is in normal operation. The fault signal will be produced and flashing the yellow fault LED on the receiver.

5.2.2. After adjustment/re-initialisation

The beam detector will produce a fault after or during adjustment for one of the following reasons :-

- ▶ The receiver cover has been left open for three hours
- ▶ The cover of the receiver was closed, but the sensitivity was left OFF
- ▶ The light level is too low reaching the beam
- ▶ The light level is too high reaching the beam
- ▶ The sensitivity has been set but the cover of the receiver was not closed within 5 minutes
- ▶ Synchronization with the emitter is not successful

5.2.3. During normal operation

The beam detector will produce a fault during normal operation for one of the following reasons :-

- ▶ The limit of contamination has been reached. The detector is only able to compensate for contamination or alignment change up to a certain point
- ▶ The obscuration is greater than 90% (a fire alarm signal will also be produced (This can be changed by configuration. See Chapter 2.6.2.))
- ▶ The receiver has come out of synchronization with the emitter. (Synchronization with the emitter is compensated for at intervals of five minutes or so. If the emitter alone is turned off and back on, or if the beam is blocked for more than 30 minutes, compensation will lag behind, resulting in a fault.)

5.3. Indication of normal operation

When the covers of the receiver or emitter are closed then the green LED visible through the outside of the case will flash every 3 seconds to indicate that the detector is operating correctly.

If the cover of the receiver is open then both green LED's (the centre alignment LED is not visible unless the cover is open) on the receiver will flash every 3 seconds. If the cover of the emitter is open then both green LED's (the centre alignment LED is not visible unless the cover is open) on the emitter will flash every 3 seconds. The rate of flash will not be affected by opening the cover of the detector.

5.4. Sensitivity and operation setting

The receiver is provided with a DIP switch with 4 bits available for setting the sensitivity and operation of the beam detector. Bits 1 and 2 are allocated to sensitivity setting, while bits 3 and 4 are allocated to settings by operation type. The sensitivity settings can be 25%; 50%; 70% or adjustment. For operation types, bit 3 can be set to switch the signals to be emitted when the beam is blocked to fault and fire, or to fault alone. Bit 4 can be set to switch between the automatic or manual recovery from the fault status. For details, see Chapter 2.6.2.

The sensitivity setting only affects the determination of the fire signal. Basically the higher the percentage setting, the less sensitive the beam detector will be since the production of a fire signal requires that the signal seen by the receiver should be reduced by more than the amount of the sensitivity setting. For example a sensitivity of 25% requires a reduction of the signal by 1/4 of its initial value to produce a fire.

The fault states to be manually recovered from are faults occurring during normal monitoring (dimmed by more than 90%, compensation limit reached, and out of synchronization). Similarly to fires, these faults can be recovered from by pressing the recovery button* on the receiver.

*The conditions for manual recovery are specified in clause 6. If the conditions are unmet, use manual recovery.

5.5. Total obscuration of the beam

If the beam detector is totally obscured, a fault signal will be produced. The fault condition will disappear when the total obscuration condition is removed. The operation type can be set with SW4 (refer to figure 11).

5.6. Automatic compensation for change of receiver's signal strength

From the time that the beam detector is initialised, the signal at the receiver is checked every 30 minutes for variation and will be altered by $\pm 1\%$ back towards the original stored value. The beam detector will store the initialisation value, when either the cover is closed after the sensitivity has been set (sensitivity not in the no operation position). If the power is turned off and back on with the receiver cover closed, the compensation percentage before the power was turned off will be read from the internal memory and the operation will continue. The compensation percentage can be cleared either by opening the receiver cover while being energized or by turning the power on with the receiver cover open.

6. Specification

Installation Environment	Indoor use only
Principle of Operation	Light beam obscuration(near infra-red)
Rated Voltage	24VDC
Rated Current	50mA(power line) , 0.5A(zone)
Operating voltage range	Emitter : 15~41VDC Receiver : 15~33VDC
Peak surge voltage	42V
Supervisory current(average)	Emitter : 50 μ A (at 24V,25°C) Receiver : 200 μ A (at 24V,25°C)
Compensation method	1% every 30mins. towards initial value
Compensation limits	+50% to -50% of the initial value
Fire condition	Red fire LED on receiver illuminated and fire relay closes
Fault condition	Yellow fault LED on receiver flashes and fault relay opens
Monitor condition	Set up condition : Both green and yellow LED's flash Normal operation : Green LED flashes
Monitor condition flash repetition time	1 per 3 seconds
Minimum time needed to reset from fire	100msec
Minimum time needed to reset from fault (manual reset mode)	100msec (less than 7V in zone voltage)
Minimum time needed before beam can reset after fire produced	3seconds
Installation temperature range	32° F to 100° F (0°C to 37.8°C)
Maximum humidity	95% R.H. non-condensing
Coverage	32.8' to 328' (10m to 100m)
Sensitivity	25% , 50% ,70%/span obscuration
Allowable Line Resistance	50 Ω
Allowable misalignment angle(MAX)	Emitter: $\pm 0.5^\circ$ Receiver: $\pm 1^\circ$
Size (emitter or receiver)	86mm \times 100mm
Weight	Emitter : 450g Receiver : 500g Metal mounting bracket : 80g
Color	White Ivory(Black lens)
Housing material	ACS resin
Mounting	Wall mounting
Connection method	Push in terminals
Wiring method	4 wire configuration

7. Sensitivity selection

If requirements or standards are provided for the sensitivity of the photoelectric beam detector and a test filter, the selection of sensitivity and its test should be performed in accordance with them. Otherwise, set the sensitivity select switch so that the sensitivity falls within the sensitivity setting range recommended by the manufacturer in accordance with the monitoring distance. See table 3.

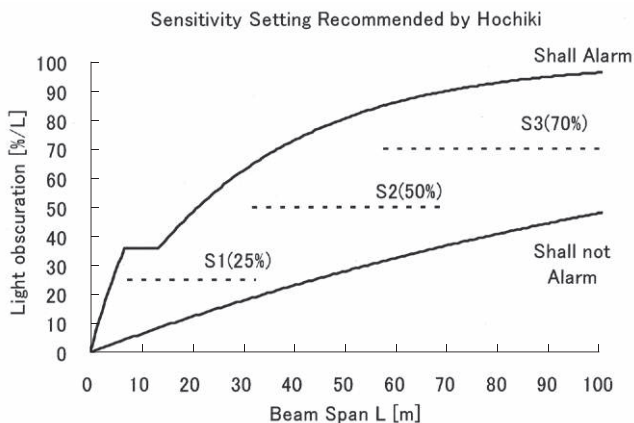

Beam Span	Recommended Sensitivity (Light Obscuration Percentage)
10~32.1m	S1(25%)
31.8~67.9m	S2(50%)
57.5~100m	S3(70%)

Table 3: Sensitivity setting for Beam span

8. Troubleshooting

The following conditions relate to the SPC-24 itself.

8.1. Operating indicator LED fails to flash

8.1.1. Receiver

The operating indicator LED should flash every 3 seconds. If it does not the reason may be as follows :-

- ▶ No power on the receiver
- ▶ Voltage to the receiver less than 15V
- ▶ Receiver is damaged

Ensure that the receiver has been powered for more than 120 seconds and that the power at the receiver is greater than 15V.

8.1.2. Emitter

The operating indicator LED should flash every 3 seconds. If it does not the reason may be as follows :-

- ▶ No power on the emitter
- ▶ Power to the emitter less than 15V
- ▶ Emitter is damaged

Ensure that the emitter has been powered for more than 120 seconds and that the power at the emitter is greater than 15V.

8.2. Fire signal continues after reset

When a fire has occurred there may be certain circumstances that will prevent the beam detector from resetting. These are :-

- ▶ There is an obstruction of the optical path between emitter and receiver. Ensure there is no obstruction.
- ▶ The optical axis has been altered suddenly. The beam will need re-alignment.
- ▶ The emitter has stopped working. Check the voltage is present at the emitter.
- ▶ Insufficient time between fire and reset. At least 3 seconds are required before resetting the beam after the fire signal has occurred.

8.3. Fault signal cannot be reset

If a fault has been generated without any obvious reason, it has occurred due to one of the following reasons :-

- ▶ Contamination limit has been exceeded (light received has changed by more than 50%)
- ▶ The CPU is unable to initialise the detector correctly as the values read are out of range
- ▶ The detector cover has been closed without setting the sensitivity
- ▶ The detector cover has been opened
- ▶ The optical axis has been altered suddenly.
- ▶ The emitter has stopped working.
- ▶ The distance switch of the emitter has been incorrect position
- ▶ The emitter is out of synchronization with the receiver

To clear these conditions the set up and adjustment procedure should be repeated.

8.4. Detector generates fire - panel does not register condition

- ▶ The zone is incorrectly wired to the beam detector. The wiring must be done in accordance with the relevant wiring diagram

8.5. Detector generates a fault - panel does not register condition

- ▶ The zone is incorrectly wired to the beam detector. The wiring must be done in accordance with the relevant wiring diagram

9. Installation guide lines

Detectors must be installed and maintained in accordance with applicable NFPA standards, local codes and any authority having jurisdiction. Refer to NFPA 72 "National Fire Alarm and Signaling Code" for installation guidelines and testing procedures. Smoke detectors should be tested in accordance with NFPA 72, section on "Inspection, Testing and Maintenance".

9.1. General installation conditions

The following diagram relates to the typical installation condition i.e. in a long straight area and details the siting positions of the beam detector.

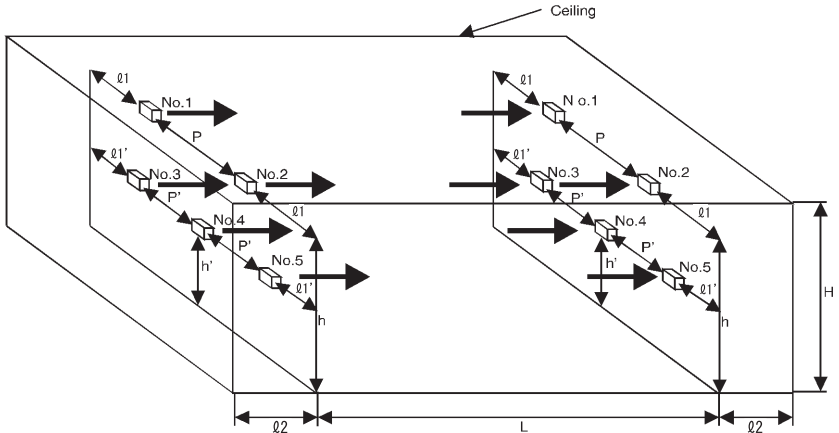

H=ceiling height h=mounting height
 l_1 =side wall distance l_2 =back wall distance
 P=distance between optical axes L=distance between Emitter/Receiver

If $H \leq 26$ feet: use No.1 and No.2 locations

If $H > 26$ -60 feet: Consider locations 3, 4 and 5 when possible

For Detectors at 1 and 2	For detectors at 3, 4 and 5
$h \geq 0.8H$	$h' = H/2$
$l_1 \leq 30\text{ft}$	$l_1' \leq 15\text{ft}$
$l_2 \leq 15\text{ft}$	
$P \leq 60\text{ft}$	$P' \leq 30\text{ft}$
$L = 32.8 \text{ to } 328\text{ft}$	$L = 32.8 \text{ to } 328\text{ft}$

Figure 14 General installation conditions

9.2. Installation in Saw-tooth type ceilings

In installations where there is a saw-tooth shape to the ceiling the detectors should be mounted with the axis either in condition A or condition B according to Figure 15. If the height of the ceiling 'a' is greater than $0.2'H'$ do not install with the axis according to line B.

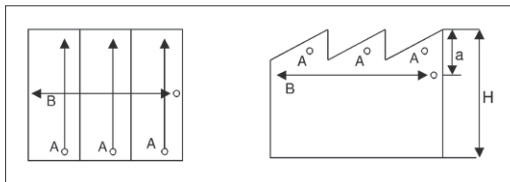

Figure 15 Installation in saw-tooth shaped roofs

9.3. Installation in circular type ceilings

The installation in a cylindrical or circular roofed building should be in accordance with. In the case of the cylindrical roof position A or B for the detector's axis is acceptable.

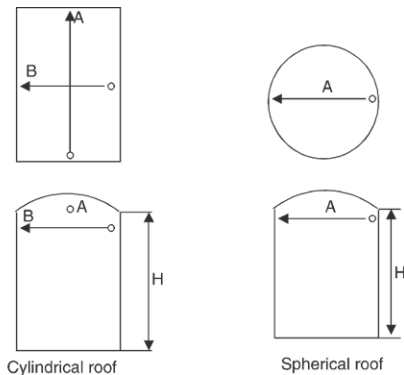

Figure 16 Installation in circular shaped ceilings

9.4. Installation in sloped ceilings

The installation for a sloped type roof or ceiling will be as shown in Figure 17. Either position A or B is acceptable for installation of the SPC-24.

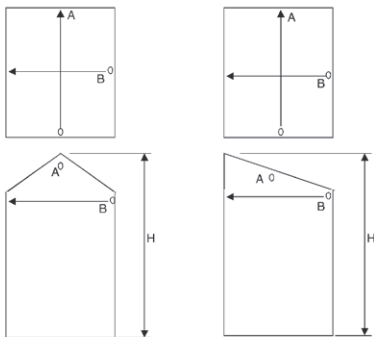

Figure 17 Installation under a sloped ceiling

9.5. Installation in a monitor roof

The installation for a monitor roof should be performed as in Figure 18. The detector's installation height should be $0.8H$ or higher. If there is a ventilation in the top part of the roof then the detector must be placed below the opening. The detector should be installed in accordance with the following height restriction : $H-a > h \geq 0.8H$

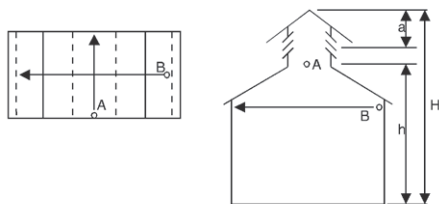

Figure 18 Installation in a monitor roof

9.6. Installation in corridors or aisles

9.6.1. Closed corridor

When the detector is installed in a corridor with a closed corner it is possible to use just one detector as shown in Figure 19 providing that the distance L is less than $23'$.

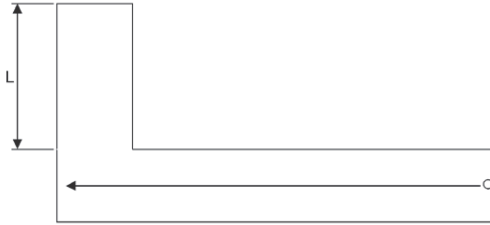

Figure 19 Installation in a closed corridor

9.6.2. Corridor with open adjoining aisle

When the detector is installed in a corridor with an area adjoining which is open as shown in Figure 20 it is necessary to consider the adjoining area as a separate detection area.

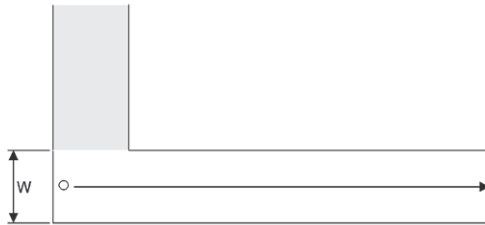

Figure 20 Installation in an open corridor

9.6.3. Corridor with corners

When the detector is installed in a corridor with a bend and an aisle as shown in Figure 21 it will be necessary to use at least 2 beam detectors to cover the corridors. If the distance P is greater than 46' then another beam detector will need to be installed at point C.

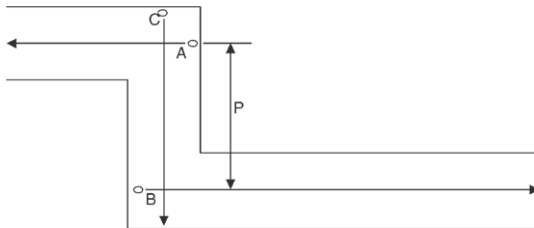

Figure 21 Installation in a corridor with corners

9.7. Installation precautions

The following precautions are necessary when installing beam detectors:-

- In a room where an air inlet is positioned in the ceiling the beam detector should be placed near to the air inlet.
- Select an appropriate installation place where the detector is unaffected by air being drawn into a ventilated opening.
- The distance between the receiver and the wall immediately behind the receiver should be less than 11.5'.
- If more than one detector is installed they must be positioned in such a manner that they cannot affect each others operation.
- The detector should be positioned such that it will not be affected by a shutter or hanging wall.
- The detector should be positioned such that it will be unaffected by moving objects.
- The detector should not be installed in a roof top or place where open air circulates.
- The detector should be installed where the distance between top and bottom of the space is greater than 1.7'.
- The monitoring distance between the emitter and receiver is 32.8' to 328' and the maximum distance of coverage between the line of the beam is 23'.
- If there is a probability of people walking in the area of the beam then the beam detector should be installed at least 9' from the floor.
- The beam detector should not be installed at a height greater than 82' unless the fire detection system is connected directly to the fire brigade or via a central station and rapid attendance by the fire brigade is possible. In any case the maximum installation height is 131'.

9.8. Smoke Patterns

The following smoke patterns should be considered when considering beam detector installation:

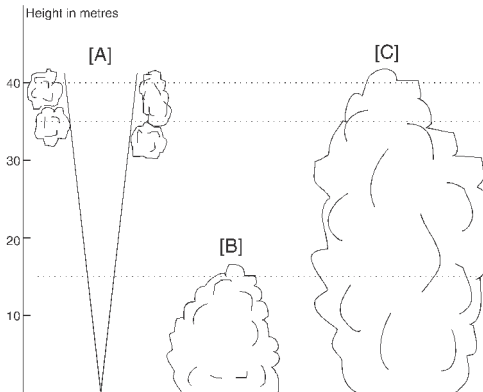

[A] This pattern is produced by hotter burning fires and is very narrow at ground level. Therefore it may be easier to detect at a higher level or at the ceiling

[B] This type of smoke produced by a smouldering fire will not rise above 15m and therefore to cover this type of risk it is necessary to install the detector below 15m

[C] This smoke pattern will be detected by detectors installed at any height

Figure 22 Typical smoke patterns

Hochiki America Corporation
7051 Village Drive, Suite 100
Buena Park, CA 90621-2268 USA
Tel (714) 522-2246
Fax (714) 522-2268

Technical Support
Tel: (800) 845-6692
Fax: (714) 690-7890
E-MAIL: technicalsupport@hochiki.com

2-8-001-2797-152

DWG. # HA-06-174
Page 28 of 28 6/20
Part # 1700-09917